

FULL HYDRAULIC COMPACT EXCAVATOR

TB210R

Operating Mass : 1150kg



TAKEUCHI



FULL HYDRAULIC COMPACT EXCAVATOR

TB210R

Operating Mass : 1150kg

TAKEUCHI

POWERFUL & COMFORTABLE

SPECIAL FEATURES

JOBSITE TOUGH

The top mounted hydraulic boom cylinder and internally routed hoses are protected from potential damage. These features help increase durability for a longer service life.

POWERFUL ENGINE (3cylinder/8.7kW) **21% Increase**

Best in class engine output due to the 21% improvement over TB108 in power. Machine performance is greatly enhanced, while noise output has been reduced.

IMPROVED DIGGING POWER

10% Increase

over TB108 in arm and bucket breakout forces

IMPROVED WORKING RANGE

10% Increase

over TB108 in reach and depth

HYDRAULIC JOYSTICK CONTROL

Pilot controlled joysticks are responsive and reduce operator fatigue enhancing work efficiency and productivity. This design now sets the standard for machines in this class.

AUXILIARY HYDRAULIC PEDAL (STOWABLE)

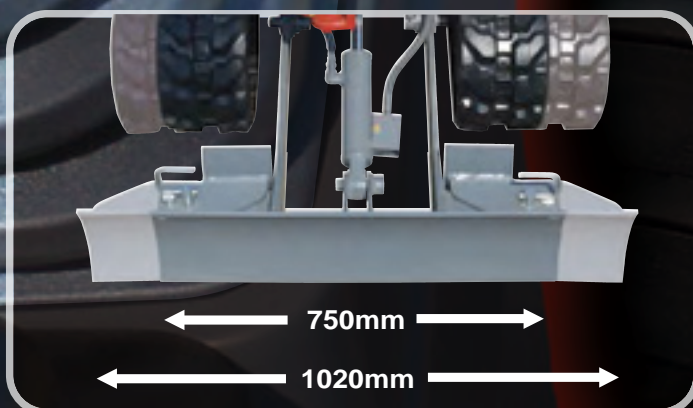

RETRACTABLE UNDERCARRIAGE AND BLADE

Blade extensions are removable using a single pin, and the track frame can be adjusted hydraulically from 750mm to travel through narrow spaces, to 1020mm for outstanding stability.

THROTTLE LEVER

OPTIONS

PATTERN CHANGE VALVE (ISO⇌G) : 2WAY LEVER

TRAVEL ALARM

TB210R FULL HYDRAULIC COMPACT

TRAVEL
LEVER

TWO-SPEED TRAVEL



HOUR METER

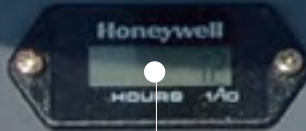

EXTERNAL POWER
SOCKET(12V/5A)

WARNING LAMPS / INDICATORS

610mm between joysticks (Actual Size)



BOOM SWING ANGLE (85/85)

COMPACT EXCAVATOR

SERVICEABILITY

- FULLY OPENING ENGINE COVER
- EASY ACCESS TO DAILY MAINTENANCE POINTS
- SIGHT GAUGE FOR HYDRAULIC OIL LEVEL



BLADE LEVER

SAFETY

- FOLDING CANOPY WITH CERTIFIED ROPS PROTECTION
- SLEW LOCK
- RETRACTABLE SEATBELT
- CONSOLE SAFETY LOCKOUT

HORN BUTTON

BOOM SWING PEDAL (STOWABLE)

OPERATOR COMFORT

- COMPACT DIMENSIONS
- SHORT TAIL MACHINE
- DETENT
- TWO-SPEED TRAVEL SWITCH
- HYDRAULIC SELECTOR VALVE (1WAY⇌2WAY)
- DOUBLE FLANGE TRACK ROLLER
- WIDE INDEPENDENT BOOM SWING 85 degrees to the left and right.
- ACCUMULATOR
- DOUBLE ELEMENT
- STOWABLE PEDALS

FULL HYDRAULIC COMPACT EXCAVATOR

TB210R

Operating Mass : 1150kg

Operating Range

| | |
|---|------|
| A | 3285 |
| B | 3220 |
| C | 1755 |
| D | 1475 |
| E | 2265 |
| F | 2985 |
| G | 2120 |
| H | 625 |
| J | 250 |
| K | 175 |

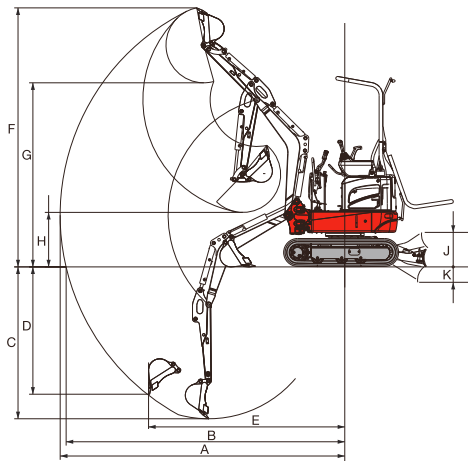

Dimensions

| | |
|----|------|
| A | 2955 |
| B | 750 |
| C | 2190 |
| D | 610 |
| E | 395 |
| F | 1005 |
| G | 1325 |
| H | 750 |
| H2 | 1020 |
| J | 180 |
| K | 160 |
| L | 1320 |
| M | 980 |
| P | 505 |
| Q | 510 |
| R | 750 |
| R2 | 1020 |
| S | 200 |
| T | 2245 |
| U | 930 |
| V | 85° |
| W | 85° |
| X | 3415 |
| Y | 1475 |

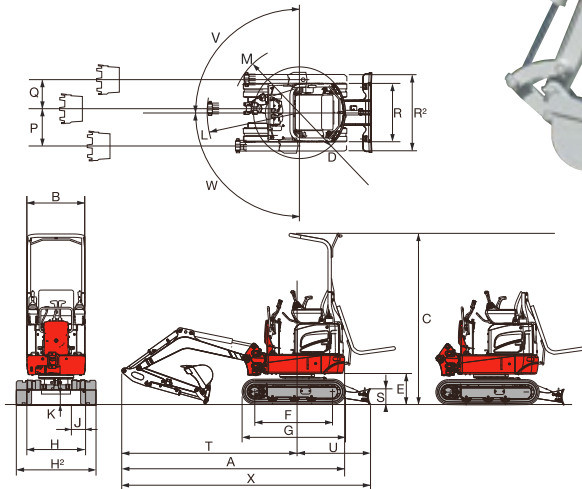

SPECIFICATIONS

| Basic Specifications / Dimensions | | | Boom Swing Angle Left/Right | |
|---|----------------|--------------|------------------------------------|-------------------------------------|
| Operating Mass | kg | 1150 | deg | 85/85 |
| Bucket Capacity (Heaped) | m ³ | 0.022 | mm | 250/175 |
| Engine Manufacturer | - | KUBOTA | kN | 11.2 |
| Engine Model | - | D722-E4B | kN | 6.4 |
| Rated Output (ISO 9249) | kW/min-1 | 8.7/2200 | mm | 880 |
| Fuel Tank Capacity | L | 12 | Boom Cylinder Layout | |
| Overall Length | mm | 2955 | Rear | |
| Upperstructure Overall Width | mm | 750 | Hydraulic Performance | |
| Overall Height | mm | 2190 | Pump Type | Double Gear Pump + Single Gear Pump |
| Crawler Overall Length | mm | 1325 | Main Relief Valve Pressure Setting | MPa 18.2 |
| Crawler Overall Width | mm | 750/1020 | Hydraulic Pump Delivery | L/min 2×11.1+1×5.8 |
| Dozer Blade Width×Height | mm | 750/1020×200 | Hydraulic Oil System | L 15 |
| Slew Radius | mm | 610 | Set Pressure P1/P2 | MPa 18.2 |
| Crawler Shoe Width | mm | 180 | Set Pressure P3 | MPa 3.4 |
| Ground Clearance of Undercarriage | mm | 160 | Service Port 1 Flow Rate | L/min 22.0 |
| Operating Ranges / Digging force | | | Slew Speed | min-1 10.0 |
| Maximum Digging Depth | mm | 1755 | Travel Speed (1st/2nd) | km/h 2.0/3.7 |
| Maximum Reach | mm | 3285 | Maximum Tractive Force | kN 12.8 |
| Equipment | | | ROPS/TOPS/FOPS/OPG | |
| | | | ○/○/—/— | |

TAKEUCHI

WORLD CREATOR OF COMPACT EXCAVATOR
TAKEUCHI MFG.CO.,LTD.
 205, Uwadaira,Sakaki-machi, Hanisina-gun.
 Nagano 389-0605,Japan
 Phone (81)268-81-1112
 Telefax (81)268-81-1121
 URL <http://www.takeuchi-mfg.co.jp>
 E-mail:marketing@takeuchi-mfg.com

 **Semco**[®]
 Since 1994 Equipment Sales

1800 685 525

www.semco-group.com.au