

FULL HYDRAULIC COMPACT EXCAVATOR

TB210R

Operating Mass : 1150kg

Operating Range

A	3285
B	3220
C	1755
D	1475
E	2265
F	2985
G	2120
H	625
J	250
K	175

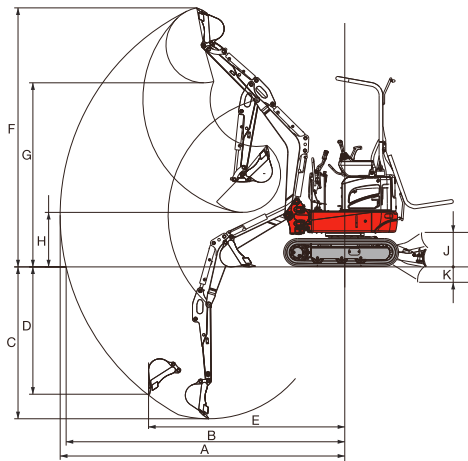

Dimensions

A	2955
B	750
C	2190
D	610
E	395
F	1005
G	1325
H	750
H2	1020
J	180
K	160
L	1320
M	980
P	505
Q	510
R	750
R2	1020
S	200
T	2245
U	930
V	85°
W	85°
X	3415
Y	1475

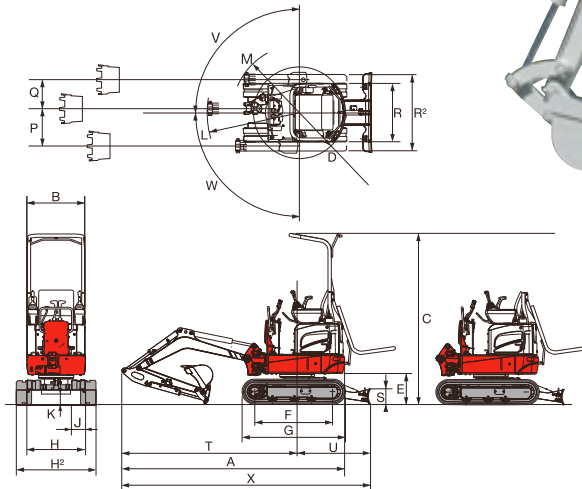

SPECIFICATIONS

Basic Specifications / Dimensions			Boom Swing Angle Left/Right	
Operating Mass	kg	1150	deg	85/85
Bucket Capacity (Heaped)	m ³	0.022	mm	250/175
Engine Manufacturer	-	KUBOTA	kN	11.2
Engine Model	-	D722-E4B	kN	6.4
Rated Output (ISO 9249)	kW/min-1	8.7/2200	mm	880
Fuel Tank Capacity	L	12		Rear
Overall Length	mm	2955	Hydraulic Performance	
Upperstructure Overall Width	mm	750	Pump Type	Double Gear Pump + Single Gear Pump
Overall Height	mm	2190	Main Relief Valve Pressure Setting	MPa 18.2
Crawler Overall Length	mm	1325	Hydraulic Pump Delivery	L/min 2×11.1+1×5.8
Crawler Overall Width	mm	750/1020	Hydraulic Oil System	L 15
Dozer Blade Width×Height	mm	750/1020×200	Set Pressure P1/P2	MPa 18.2
Slew Radius	mm	610	Set Pressure P3	MPa 3.4
Crawler Shoe Width	mm	180	Service Port 1 Flow Rate	L/min 22.0
Ground Clearance of Undercarriage	mm	160	Slew Speed	min-1 10.0
Operating Ranges / Digging force			Travel Speed (1st/2nd)	km/h 2.0/3.7
Maximum Digging Depth	mm	1755	Maximum Tractive Force	kN 12.8
Maximum Reach	mm	3285	Equipment	
			ROPS/TOPS/FOPS/OPG ○/○/-/-	

TAKEUCHI

WORLD CREATOR OF COMPACT EXCAVATOR
TAKEUCHI MFG.CO.,LTD.
 205, Uwadaira,Sakaki-machi, Hanisina-gun.
 Nagano 389-0605,Japan
 Phone (81)268-81-1112
 Telefax (81)268-81-1121
 URL <http://www.takeuchi-mfg.co.jp>
 E-mail:marketing@takeuchi-mfg.com

 **Semco**[®]
 Since 1994 Equipment Sales

1800 685 525
www.semco-group.com.au